

Armrest Replacement Notes:

- Due to a product enhancement, as of Serial Number JC711024216020, the upright (A3) and receiver (A4) have been updated to a new version.
- Version 1 and version 2 components are incompatible. Therefore, when replacing a version 1 receiver block (D1), it is necessary to replace both the version 2 upright (A3) and receiver block (A4).
- If replacing one side, it's recommended that the other side is also replaced, though it is not necessary.
- Only parts with callouts are available for replacement. For parts without callouts, the complete assembly must be selected.

HD Removable Armrest Assembly, 10"-14"H, Full Length

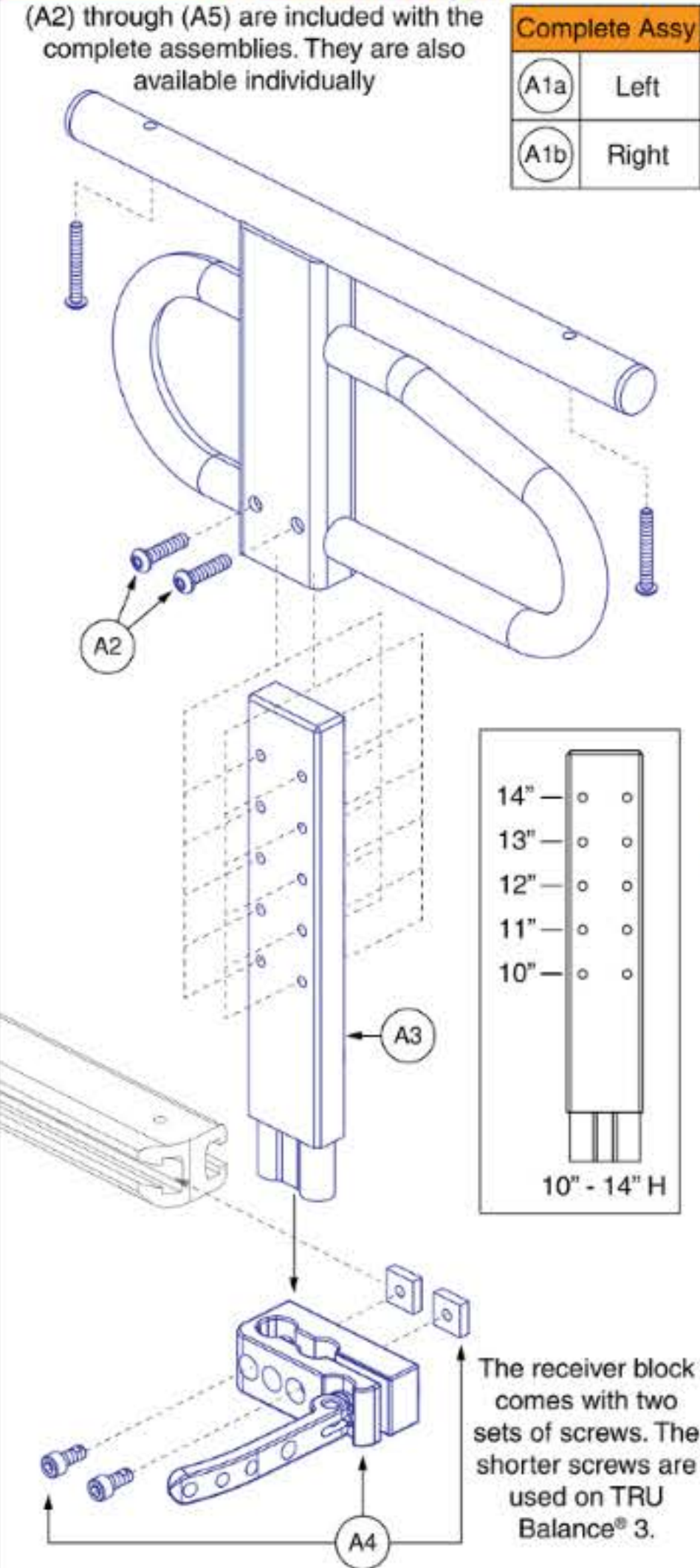

Full Length Armpads and Replacement Screws

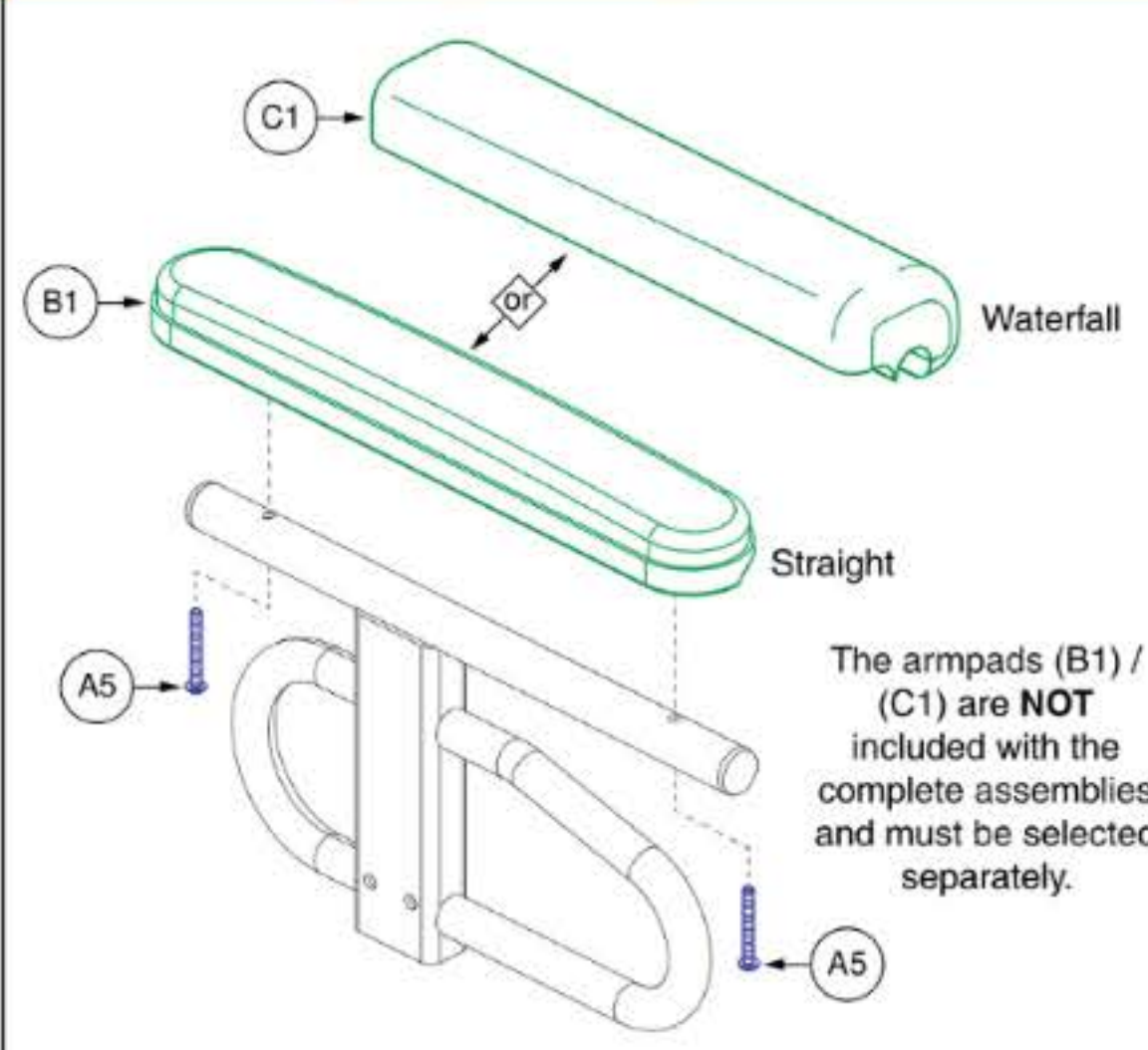

Version 1 Receiver Block (See Notes)

